

THE
GRAINFATHER
ALL GRAIN BREWING

G70

ELECTRIC BREWING SYSTEM



QUICK START GUIDE

THANK YOU FOR CHOOSING THE GRAINFATHER G70.

Now let's get the equipment ready with a few quick and easy steps and you will be brewing in no time.

NOTE: These are shortened instructions for product assembly only.



Please note that a two-man or mechanical lift is required when using this system. The grain basket can weigh up to 60kg when in use and a single person lift may lead to serious injury.

We highly recommend that you read the full, detailed instructions found at the Grainfather online store shop.grainfather.com

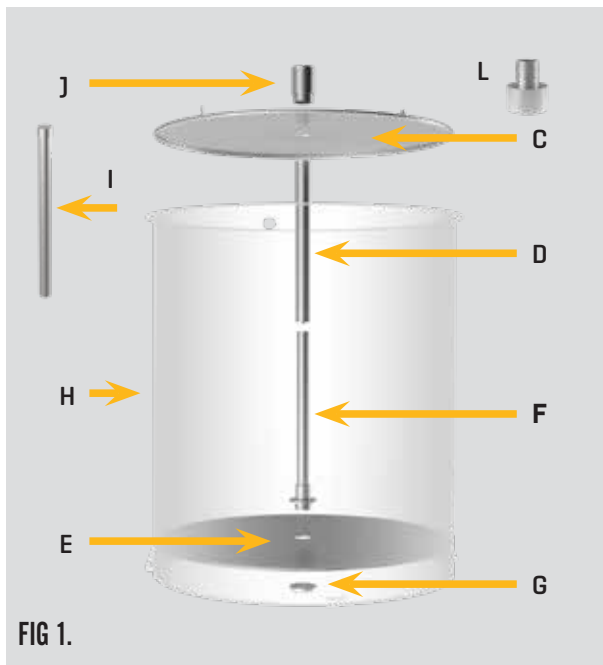

PARTS LIST:

- A. Post Boil Cleaning Filter
- B. Hop Filter
- C. Top Plate
- D. Top Overflow Pipe
- E. Bottom Plate
- F. Bottom Overflow Pipe
- G. Overflow Nut
- H. Grain Basket
- I. Grain Stopper
- J. Overflow Inlet
- K. Smart Controller
- L. Sight Glass
CIP Connection
- M. Counterflow Chiller

ALSO INCLUDED:

- 1. Recirculation Barb and Hose
- 2. Tap and O-ring
- 3. Lifting Bar
- 4. Hex Cap to use in place of sight glass
- 5. Spares pack (o-rings)



We recommend that you clean your G70 before the first use. Refer to the Cleaning Section of this guide for instructions.

PRE-BREWING ASSEMBLY

1. INSTALL THE HOP FILTER

Take the hop filter (B) and place it on the inside base of the G70 boiler body (Fig 2.). It should fit tightly. Apply pressure to make sure it's securely in place.

Note: It is important to install the hop filter before brewing. Brewing without the hop filter may allow material to block the pump.

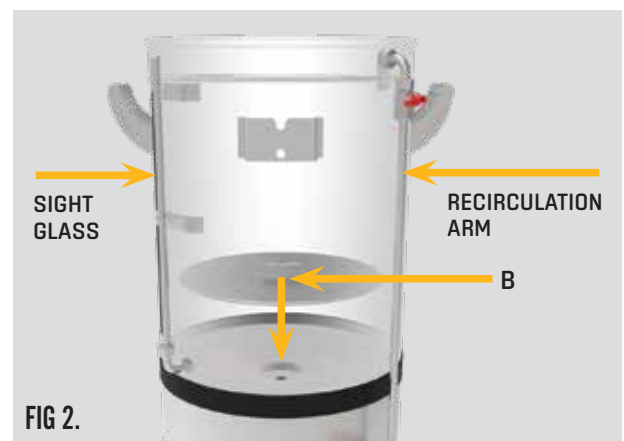

CONNECTING THE CONTROLLER AND POWER

2. ATTACHING THE CONTROLLER.

Take the Grainfather smart controller (K) and M12 power cable from its packaging and place it securely on the front bracket (Fig 3). Next remove the small cap from the M12 socket located at the front lower section of the G70 unit. Then place the M12 cable into the socket, making sure that the right angle connector is facing upwards. Finally, tighten the securing nut.



3. CONNECT POWER

Take the main power cable and plug it into the base at the back of the G70 unit. Next plug the other end of the cable into the professionally installed 230V 15A (13A in UK) power socket. The controller should now receive power and the display will turn on. If this does not occur, please check both the M12 controller cable and the main power cable are securely connected.

4. ADVANCED WIRELESS CONNECTION AND APP CONTROL

At this point you will be able to use your new Grainfather G70 and complete a brew using the smart controller. However, the G70 is designed with smart features, wireless connectivity and access to the Grainfather Brewing Community which are all accessible after setting the controller up on your local wireless network. For detailed instructions on how to do this please head to the Grainfather online store - shop.grainfather.com

SETTING UP TO BREW

5. PREPARATION, ADDING WATER

After all the steps above have been completed you are ready to start a brew. Based on your recipe, calculate the required amount of mash water then add it to the G70. You can use the advanced calculators available on the Grainfather Community Mobile App or Web Tools. Note: Make sure your G70 is on a stable, flat surface before you start.

6. PRIMING THE PUMP

Open the top valve on the recirculation arm and turn the pump on to circulate water through the pump. If no flow occurs through the recirculation arm, turn the pump off, wait 1 minute, and turn the pump back on. If no flow occurs after a second attempt, close the top valve, place a container under the bottom ball valve, turn the pump on and fully open the bottom ball valve to help clear any air trapped in the system.

7. SET THE MASH/STRIKE TEMPERATURE

Using the controller set the required mash temperature and press the 'Heat' button to initiate heating. Place the lid on the unit to speed up the heating time. You can also use the Grainfather Community App to connect with the controller and run your brew session remotely on your device.

8. ASSEMBLE THE BOTTOM GRAIN BASKET COMPONENTS

Take the bottom plate (E) with the rolled edge facing down, insert the bottom overflow pipe (F) onto the top of the bottom plate. Next, screw the overflow nut (G) onto the bottom overflow pipe as seen in Fig 1.

9. INSERT THE BOTTOM COMPONENTS INTO THE GRAIN BASKET

Insert the newly assembled bottom components from step 7. into the grain basket, making sure you have assembled them so that the bottom plate has its rolled edges facing down. Next push the top overflow pipe (D) securely over the bottom overflow pipe, making sure that the wire springs are orientated at the bottom end facing down (Fig 4).



10. ADD GRAIN BASKET AND OVERFLOW PIPE ASSEMBLY

Slowly insert the assembled grain basket (Fig 5) into the boiler, making sure that the top overflow pipe is fully extended. Once the water has reached the required temperature, insert the grain stopper (I) into the top overflow pipe (Fig 6). The grain stopper has a rolled edge to show the maximum level the top overflow pipe can extend without pulling off.



11. ADD GRAINS AND STIR

Slowly add the grain to the grain basket, stirring well to avoid any dry clumps.

12. INSTALL TOP PLATE AND OVERFLOW INLET

Fit the top plate (C) down using the extended hand pieces, until it rests just on the top of the grain bed. Make sure it is level and does not compress the grain. Next, remove the grain stopper and fit the overflow inlet (J) onto the top overflow pipe, press down until it fits into the hole of the top plate – but do not press too hard.



13. INSTALL THE RECIRCULATION HOSE

Locate the recirculation barb and hose. Make sure the hose is securely attached to the recirculation barb (Fig 7) and insert the barb into the G70 body. Thread the hose through one of the holes in the handle of the top plate, orienting the end of the hose to form a gentle whirlpool.

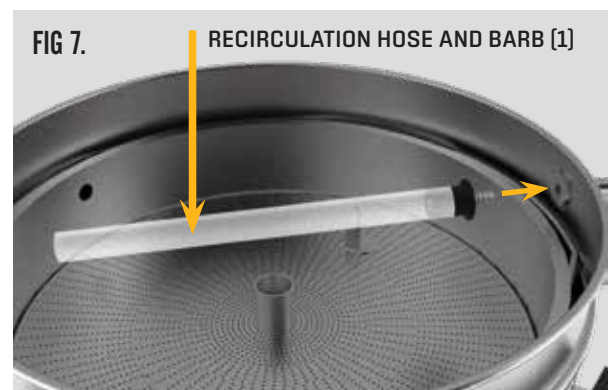

14. RECIRCULATE

Open the valve on the top of the outside recirculation arm. Then activate the pump using the button on the controller or via the Grainfather Community App to start recirculating. Adjust the valve so that the wort flow is restricted and the wort level is just above the overflow inlet, allowing a small amount of wort to overflow through the overflow inlet.

LIFTING THE BASKET AND SPARGING

CAUTION!

TWO MAN OR MECHANICAL LIFT REQUIRED. Basket can weigh up to 60 kg (132 lbs) during use. Please do not attempt to single person lift as this could lead to serious injury.



BE VERY CAREFUL not to twist the basket while the basket is in the sparge position which could knock it off the support ring. If the sparge is “stuck” (not draining), then remove the top perforated plate and slice the grain bed with a stainless paddle or similar item. Cut through the stuck mash from the center towards the outside repeatedly until it starts draining. This should keep the basket safely located on the support ring. Do not stir the grain bed as this could twist the basket off the support ring.

Always ensure the support ring fits tightly into the groove and is held securely in place by the support ring retaining plate.

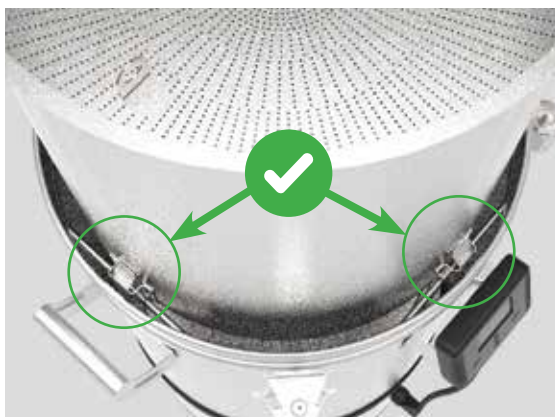
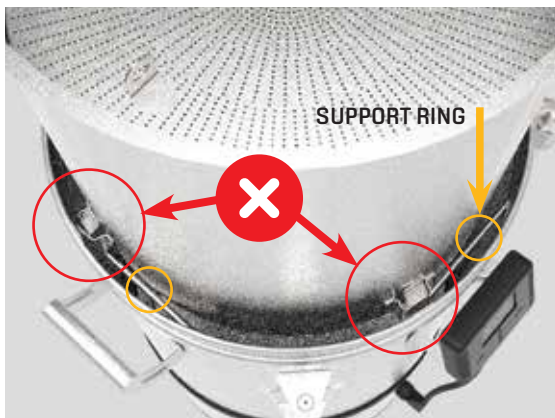

15. USING THE LIFTING BAR

When the mash is finished, turn off the pump and remove the recirculation hose. Insert the basket lifting brackets into the holes in the basket. With one person holding each side of the lifting bar, lift the basket. Turn it 45° so that the feet at the bottom rest on the basket support ring.



FIG 8.

16. SPARGING AND BASKET REMOVAL

Allow the mash liquid to drain into the boiler, gently press down on the overflow inlet until the top plate rests on the grain. Gently pour the sparge water evenly over the grain and allow to drain until water is a few mm above the top plate. Using the same method described in the previous point, lift and remove the entire grain basket with grain from the boiler. If you are using a large grain bill, it is recommended to gently scoop some grain out of the basket to reduce the weight. You can now continue with the brewing process.

17. COOLING WITH THE COUNTERFLOW CHILLER

The Grainfather G70 system includes a counterflow chiller (M) designed to efficiently cool the wort for transfer into a fermenter. At the end of the boil, circulate hot wort through the counterflow chiller for 30-60 seconds, but no longer, to sanitise it. Then stop the pump, ensure hoses are not kinked, the chiller is not sitting on top of them, and that water can flow freely, then gradually turn on your cooling water and adjust the flow rate. Allow the cooling water to flow for 2 minutes, then turn on the pump and transfer your wort through the counterflow chiller into your cleaned and sanitised fermenter.

*Note: On your first use, run cleaner through the chiller before use by connecting it to the G70 during instruction ‘C’ in the cleaning instructions in this quick guide.

CLEANING THE G70

A. REMOVE EXCESS LIQUID FROM THE BOILER

If there is any excess liquid in the boiler, follow these steps to clear it:

- Close the ball valve at the top of the recirculation arm.
- Place a container underneath the ½” ball valve at the bottom of the recirculation pipe.
- Open the bottom ball valve.
- Turn on the pump until all the liquid in the boiler is cleared.

B. REMOVE TRUB FROM THE BOILER

Remove the hop filter by lifting it with the handle. The filter is designed to take any hop debris (trub) with it, so try to scrape as much of the hop debris onto the hop filter as possible. Once the hop filter is removed, there may still be some hop debris. Insert the Post Boil Cleaning Filter (A) into the cavity on the G70 boiler base. Scrape/rinse any excess matter onto the cleaning filter, this is important to avoid any hop matter getting into the pump.

Remove the cleaning filter with the excess matter.

A



C. CLEANING THE BOILER BODY

Fill the boiler with clean water and the Grainfather High Performance Cleaner and heat the water.

Recirculate this water through the recirculation system and the chiller. When finished, empty the water from the bottom tap as per cleaning step A.

The Grainfather High Performance Cleaner is a CIP (Clean in Place) cleaner specially formulated to work with hard and soft metals associated with Grainfather systems and other brewing hardware. If you cannot get hold of this, PBW cleaner is also a great alternative otherwise use an alkaline, non caustic, non staining cleaning detergent that's suitable for use with stainless steel and copper. Avoid chlorine-based cleaners, and other corrosive chemicals unsuitable for stainless steel to prevent corrosion, rust or staining.

D. ADDITIONAL CLEANING

You may choose to be very thorough with the cleaning of your Grainfather G70 and we do recommend this to ensure the system performs at its best on each brew. Two other parts that may need your attention are the;

- Sight Glass - Unscrew the sight glass cap and screw on the Sight Glass CIP connection (L) to the sight glass. You can then pump cleaning liquid through the sight glass.
- Basket support ring - remove the recirculation arm nut connected to the inner side of the boiler. Next, remove the small clip fitted in the gap of the support ring. You can now remove the ring by applying pressure inwards on the ring until there is enough clearance for it to be removed carefully from the unit. Reinstall in reverse.

SAFETY INSTRUCTIONS

- Read all instructions before using the Grainfather G70.
- If the supply cord is damaged, it must be replaced by the manufacturer, its service agent or similarly qualified persons in order to avoid a hazard.
- This appliance is intended to be used in household and similar applications such as staff kitchen areas in shops, offices and other working environments; farm houses and by clients in hotels, motels and other residential type environments; bed and breakfast type environments; catering and similar non-retailed applications.
- The appliance is for indoor use only.
- The appliance is not suitable for installation in an area where a water jet could be used.
- The appliance must not be cleaned by a water jet.
- The appliance must be placed on a flat surface.
- The appliance is only to be installed in locations where it can be overseen by trained personnel.
- The installation of a residual current device (RCD) having a rated residual operating current not exceeding 30 mA is advisable.
- The A-weighted sound pressure level of the appliance is below 70 dB.
- Always unplug the unit before cleaning, during storage or in the event of a fault.
- To protect against fire, electric shock and injury, do not immerse cord/plugs in water or other liquid.
- The boiler, lid and pipes reach temperature up to 100°C (212°F) and therefore must be handled with caution.
- Never move the unit while it is in operation.
- Handles on the side are only meant for transportation once the Grainfather is empty and in a cooled, non-use state.
- Two man or mechanical lift required for lifting the sparge basket. Basket can weigh up to 60 kg (132 lbs) during use. Please do not attempt single person lift.
- Access of the service area is restricted to persons having knowledge and practical experience of the appliance.
- The maximum and minimum ambient temperatures for normal use of the appliance is: -20°C (-4°F) to 40°C (104°F).
- The appliance is only for heating water and wort. Do not use the appliance to heat any other type of liquid. Please clean the appliance before and after use, following the instructions in this guide.
- Save these instructions for future reference.

THE FOLLOWING STATEMENT APPLIES TO THE GRAINFATHER G70 PRODUCT SOLD IN EUROPE.

- This appliance can be used by children aged from 8 years and above and persons with reduced physical, sensory or mental capabilities or lack of experience and knowledge if they have been given supervision or instruction concerning use of the appliance in a safe way and understand the hazards involved.
- Children shall not play with the appliance. Cleaning and user maintenance shall not be made by children without supervision.

THE FOLLOWING STATEMENT APPLIES TO THE GRAINFATHER G70 PRODUCT SOLD IN THE UNITED KINGDOM:

- This appliance can be used by children aged from 8 years and above and persons with reduced physical, sensory or mental capabilities or lack of experience and knowledge if they have been given supervision or instruction concerning use of the appliance in a safe way and understand the hazards involved. Children shall not play with the appliance. Cleaning and user maintenance shall not be made by children without supervision.
- Means for disconnection must be incorporated in the fixed wiring in accordance with the wiring rules.
- The fixed wiring insulation must be protected, for example, by insulating sleeving having an appropriate temperature rating.

THE FOLLOWING STATEMENT APPLIES TO THE GRAINFATHER G70 PRODUCT SOLD IN AUSTRALIA AND NEW ZEALAND.

- This appliance is not intended for use by persons (including children) with reduced physical, sensory or mental capabilities, or lack of experience and knowledge, unless they have been given supervision or instruction concerning use of the appliance by a person responsible for their safety.
- Children should be supervised to ensure that they do not play with the appliance.

IMPORTANT SAFEGUARDS

READ AND FOLLOW ALL INSTRUCTIONS

CAUTION - Risk of fire and electric shock. Replace only with manufacturer's cord set, part No. _SJTO

SAVE THESE INSTRUCTIONS

CAUTION:

DO NOT IMMERSE IN WATER.

READ INSTRUCTIONS BEFORE USING.

FOR COMMERCIAL & INDOOR USE ONLY.



www.grainfather.com